

IPG DRY BOX

IPG Dry Drybox for using in automated packaging and commissioning stations



High process reliability

IPG Dry Box

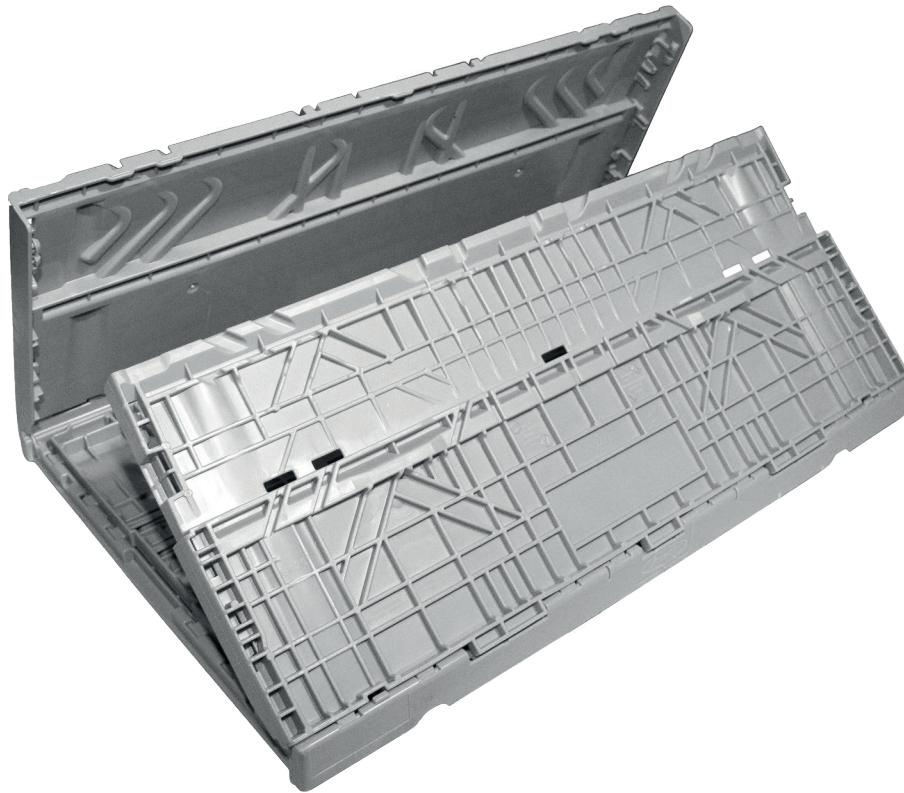

High process reliability

A central feature of this foldable box is its high process reliability. The safe and efficient processing in automated warehouses is due to safe transport on roll conveyors (horizontal and vertical), the high stability of the IPG Dry Box and its high reaction speed during acceleration and deceleration, a safe locking technique as well as its low breakage rate. In an empty state the Drybox can be reduced to a layer height of 36 mm despite its large interior height of 26 cm. This saves costs during empty transport and storage as well as during all processes involving empties.

Properties and advantages

- High process reliability in automated warehouses
- Safe and efficient transport on roll conveyors
- Robust and stable during transport and commissioning
- Safe locking technique
- Etiquette holders on the short sides
- Low breakage rate
- High useable volume, large interior height
- Can be folded down to save space

IPG Dry Box

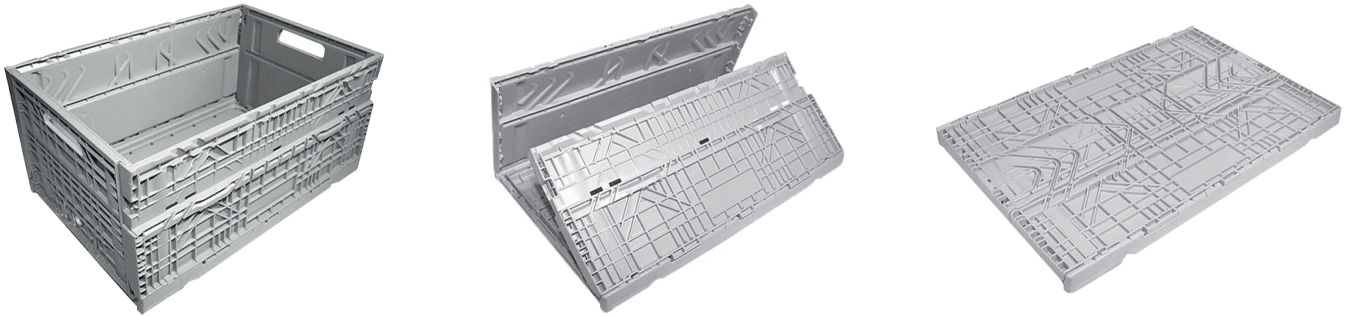

Volume reduction, foldable (optimum empties reduction, reduced transport costs)

Technical data

External dimensions [mm]	600 x 400 x 285
Internal usable dimensions [mm]	570 x 370 x 261
Filling volume [l]	55
Tare [g]	3080
Load bearing capacity [kg]	25
Pressure resistance in the stack [kg]	500
Layer height of empties [mm]	36
Number of layers/stack incl. pallet at max. height of	
approx. 2,0 m	6
approx. 2,2 m	7
approx. 2,4 m	8

Delivery units (empties) IPG Dry Box

IPG Dry Boxes /europallet	240 pcs.
Dryboxes/lorry (13,20 x 2,46 x 2,50 m)	7200 pcs.
Europallets/lorry (13,20 x 2,46 x 2,50 m)	30 pcs.
Total height incl. pallet	2310 mm
Colour	red RAL 3004 green RAL 6009 blue RAL 5005 grey RAL 7001 black RAL 9005

Technical Information:

The IPG Dry Box is suitable for temperatures ranging from 0° C to 50° C. The technical properties can be guaranteed under these conditions if handled appropriately. The pressure resistance in the stack equals a maximum of 500 kg. The raw materials used in the production of IPG Dry Box comply with the requirements of the FDA and the BGA



IPG Intelligent Packaging Group AS

Hensmoveien 46 • 3516 Hønefoss • Norway
Sentralbord: +47 38 99 40 13 • Mobil: +47 960 49 556
E-post: info@ip-group.no • www.ip-group.no

IPG Intelligent Packaging Group AB

Västrevångleden 2 • SE-302 41 Halmstad • Sweden
Switchboard: +46 35 10 24 80 • Fax: +46 35 12 71 60
Email: info@ip-group.se • www.ip-group.se